

Typical Mount Fixing Detail

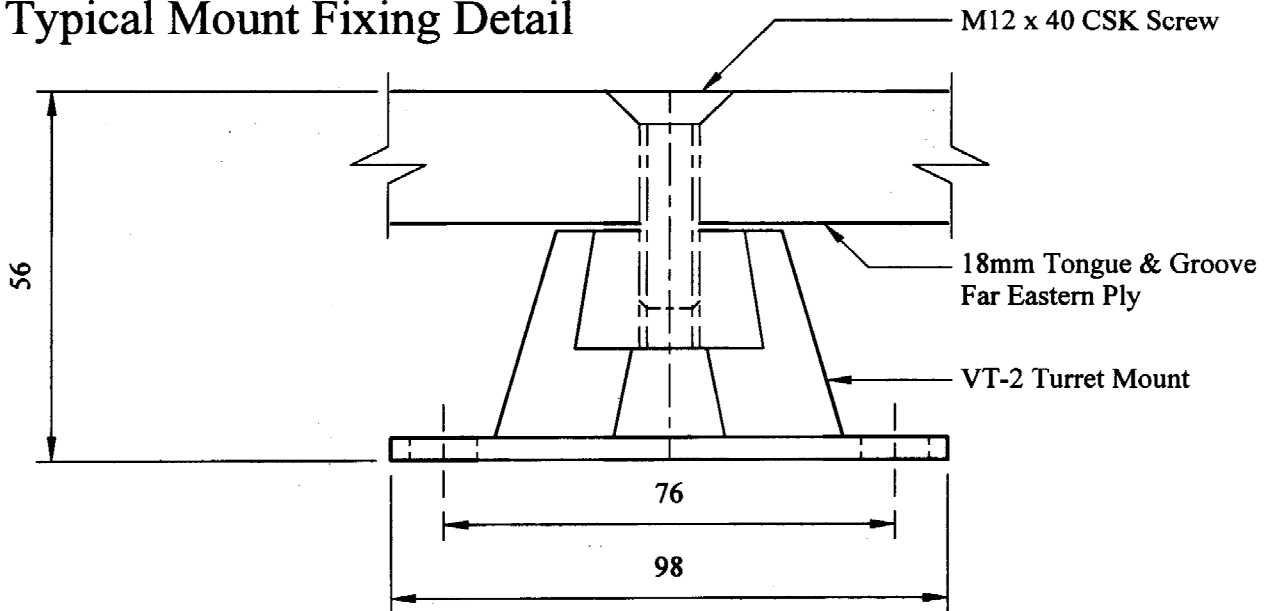

Typical Mount Fixing Centres

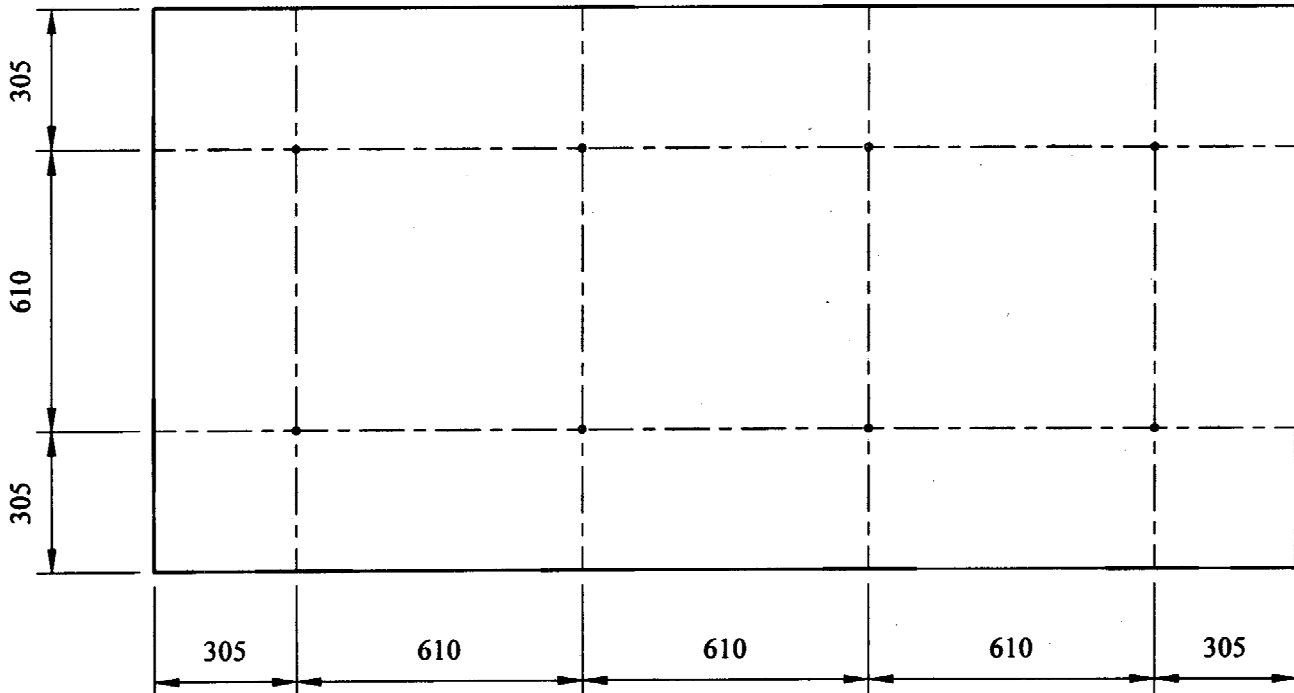

Standard Load Detail

Colour	Load kg	Fn
Blue	480	8.0 Hz
Green	865	8.0 Hz
White	1440	8.0 Hz
Red	2160	8.0 Hz
Black	2880	8.0 Hz

NOTE: ALL DIMENSIONS IN MM
 STANDARD ENGINEERING TOLERANCE +/- 1MM, UNLESS OTHERWISE STATED
 RESEARCH & DEVELOPMENT IS ONGOING & UNLESS STAMPED CERTIFIED
 (VALIDITY 3 MONTHS) THIS DATA SHEET IS ONLY CORRECT AT DATE OF ISSUE



EUROVIB (Acoustic Products) Limited

Goodwood House, 86 Holmethorpe Avenue, Redhill, Surrey RH1 2NL
 Telephone: 01737 779577 Facsimile: 01737 779537

THE COPYRIGHT OF THIS DRAWING AND THE RIGHT OF REPRODUCTION
 THEREOF IS VESTED IN AND BELONGS TO EUROVIB (ACOUSTIC PRODUCTS) LIMITED

GENERAL ARRANGEMENT DRAWING

FEP 18/VT-2 Floating Floor Isolation System

Drawing No:
 GA/031/999/Rev0

Date:
 SEPT 1999